

OpenAir™

## Air damper actuators

GLB..1E



### Electronic motor driven actuators for open-close, three-position and modulating control



- Nominal torque 10 Nm
- Operating voltage AC 24 V ~ / DC 24...48 V =
- Mechanically adjustable span between 0...90°
- Pre-wired with 0.9 m long connection cables
- Type-specific variations with adjustable offset and span for the positioning signal
- Position indication: mechanical and electrical
- Feedback potentiometer
- Self-adaptation of rotary angle range and adjustable auxiliary switches for supplementary functions

## Use

The rotary actuators are used in ventilation and air conditioning plants to regulate and shut off air dampers:

- For damper areas up to 1.6 m<sup>2</sup> (guideline; always observe damper manufacturer's data).
- Suitable for use with modulating controllers (DC 0/2...10 V), open-close or three-position controllers for air dampers or air throttles.
- We recommend a minimum pulse length of 500 ms on rotary actuators operated with three-position control to ensure continuous and accurate operation.

## Functions

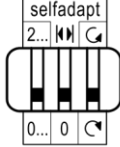
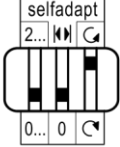
GLB..	AC 24 V ~ / DC 24...48 V –	141.1E / 142.1E / 146.1E	161.1E / 163.1E / 164.1E / 166.1E
	AC 100...240 V ~	341.1E / 346.1E	361.1E
Control type	Open-close / three-position		Modulating control (0/2...10 V)
Rotary direction	<p>Clockwise or counter-clockwise direction depends on...</p> <ul style="list-style-type: none"> <li>• ...the type of control;</li> <li>• ...the setting of the rotary direction switch:</li> </ul> <div style="display: flex; justify-content: space-around; align-items: center;"> <div style="text-align: center;"> <p><b>CW</b></p>  </div> <div style="text-align: center;"> <p><b>CCW</b></p>  </div> </div> <p>With no power applied, the actuator remains in the reached position.</p> <div style="display: flex; justify-content: space-around; align-items: center;"> <div style="text-align: center;"> <p><b>CW</b></p>  </div> <div style="text-align: center;"> <p><b>CCW</b></p>  </div> </div> <ul style="list-style-type: none"> <li>• ...the setting of the rotary direction DIL switch:</li> <li>• ...the positioning signal.</li> </ul> <p>The actuator remains in the reached position if...:</p> <ul style="list-style-type: none"> <li>• ...the control signal is maintained at a constant value;</li> <li>• ...operating voltage is lost.</li> </ul>		
Position indication	mechanical	Rotary angle position indication using a position indicator.	
	electrical	The feedback potentiometer can be connected to external voltage to indicate the position.	Output voltage $U = DC\ 0/2...10\ V$ is generated proportional to the rotary angle. $U$ depends on the rotary direction of the DIL switch setting.
Auxiliary switch	The switching points for auxiliary switches A and B can be set independent of each other in increments of 5° within 0...90°.		
Self-adaptation of linear span	-	When self-adaptation is active, the actuator automatically determines the mechanical end positions of the linear span and maps the characteristic function ( $U_0, \Delta U$ ) to the calculated linear span.	
Manual adjustment	The actuator can be manually adjusted by pressing the gear train disengagement button.		
Rotary angle limitation	The rotary angle of the shaft adapter can be limited mechanically within 0...90° with a set screw.		

**Housing**

The housing consists essentially of glass fiber reinforced plastic:

- flame retardant
- non-brominated
- non-chlorinated.

**Actuator motor / gears**

- Brushless, robust DC motors ensure reliable operation regardless of load. The damper actuators do not require an end position switch, are overload proof, and remain in place upon reaching the end stop.
- The gears are maintenance-free and low-noise.

**Type summary**

Type	Stock no.	Control	Operating voltage	Positioning signal Y	Position indicator U = DC 0...10 V =	Feedback potentiometer 5kΩ	Self-adap. of rotary angle range	Aux. switches	Rotary direction switch
GLB141.1E	S55499-D192	Open-close or three-position	AC 24 V ~ / DC 24...48 V =	-	-	-	-	-	yes
GLB142.1E	S55499-D193					yes		-	
GLB146.1E	S55499-D194					-		2	
GLB341.1E	S55499-D195		AC 100...240 V ~			-		-	
GLB346.1E	S55499-D196					-		2	
GLB161.1E	S55499-D270	Modulating	AC 24 V ~ / DC 24...48 V =	DC 0/2...10 V =	yes	-	yes	-	yes
GLB163.1E	S55499-D271			DC 0...35 V =				2	
GLB164.1E	S55499-D272			DC 0/2...10 V =				-	
GLB166.1E	S55499-D273		AC 100...240 V ~	-				-	
GLB361.1E	S55499-D197			-				-	
<b>Nominal torque</b>		10 Nm (applies to all)							

**Accessories / Spare parts**

See data sheet N4698:



<https://sid.siemens.com/v/u/A6V10405973>

## Product documentation

Topic	Title	Document ID
Data sheet	Air damper actuators	A6V10636202
Mounting instructions	GDB..1E, GLB..1E	A5W00005997

Related documents such as the environmental declarations, CE declarations, etc., can be downloaded from the following Internet address:

[www.siemens.com/bt/download](http://www.siemens.com/bt/download)

## Notes

### Safety

#### CAUTION



##### **National safety regulations**

Failure to comply with national safety regulations may result in personal injury and property damage.

- Observe national provisions and comply with the appropriate safety regulations.
- Use only properly trained technicians for mounting, commissioning, and servicing.

### Engineering

#### **Auxiliary switches and potentiometer**

Cannot be added in the field.

### Installation

#### WARNING



##### **No internal line protection for supply lines to external consumers**

Risk of fire and injury due to short-circuits!

- Adapt the line diameters as per local regulations to the rated value of the installed fuse.

### Maintenance

The actuators GLB..1E are maintenance-free

## Disposal

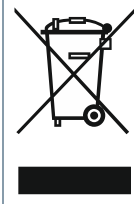

The device is considered an electronics device for disposal in terms of European Directive 2012/19/EU and may not be disposed of as domestic garbage.

- Dispose of the device through channels provided for this purpose.
- Comply with all local and currently applicable laws and regulations.

## Technical data

Power supply GLB1..1E			
Operating voltage (SELV/PELV)		AC 24 V ~ ±20 % (19.2...28.8 V ~) DC 24...48 V = ±20 % (19.2...57.6 V =) <sup>1)</sup>	
Frequency		50/60 Hz	
Power consumption	running	GLB14..1E	1.3 VA / 0.8 W
		GLB16..1E	1.5 VA / 1.0 W
	holding	GLB14..1E	0.7 VA / 0.4 W
		GLB16..1E	0.9 VA / 0.6 W

Power supply GLB3..1E			
Operating voltage (SELV/PELV)		AC 100...240 V ~ ±10 % (90...264 V ~)	
Frequency		50/60 Hz	
Power supply	running	GLB34..1E	6.0 VA / 2.0 W
		GLB36..1E	4.0 VA / 1.5 W
	holding	GLB34..1E	0.9 W
		GLB36..1E	0.6 W

Functional data	
Nominal torque	10 Nm
Maximum torque (blocked)	16 Nm
	Minimum holding torque
Nominal rotary angle (with position indication)	90°
Maximum rotary angle (mechanic limitation)	95° ±2°
Runtime for 90° rotary angle	150 s
Actuator sound power level	28 dB(A)

Inputs			
Positioning signal for GLB14..1E			
	Operating voltage AC 24 V ~ / DC 24...48 V =	wires 1-6/G-Y1	Clockwise
		wires 1-7/G-Y2	Counter-clockwise
Positioning signal for GLB34..1E			
	Operating voltage AC 100...240 V ~	wires 4-6/N-Y1	Clockwise
		wires 4-7/N-Y2	Counter-clockwise
Positioning signal for GLB16..1E			
	Input voltage	wires 8-2/Y-G0	DC 0/2...10 V =
	Current consumption		0.1 mA
	Input resistance		>100 kΩ
Max. permissible input voltage			DC 35 V = internally limited to DC 10 V =
	Protected against faulty wiring		max. AC 24 V ~ / DC 24...48 V =
Hysteresis	for non-adjustable characteristic		60 mV
	for adjustable characteristic		0.6 % of ΔU
Adjustable characteristic (GLB163.1E, GLB164.1E)			
	Adjustable with 2 potentiometers:	Offset U <sub>0</sub>	DC 0...5 V =
		Span ΔU	DC 2...30 V =
Max. input voltage			DC 35 V =
Protected against faulty wiring			max. AC 24 V ~ / DC 24...48 V =

Outputs				
Position indicator				
	Output signal GLB16..1E	wires 9-2/U-G0		
	Output signal GLB36..1E	wires 9-2/U-G-		
	Output voltage U			DC 0...10 V =
	Max. output current			DC ±1 mA
Protected against faulty wiring			max. AC 24 V ~ / DC 24...48 V =	
Aux. power supply (G-/G+)		GLB36..1E	DC 24 V = ±20 %, max. 10 mA	
Feedback potentiometer (for GLB142.1E)				
	Change of resistance	wires P1-P2	0..5000 Ω	
	Load		<0.25 W	
	Max. sliding contact current		<10 mA	
	Permissible voltage at potentiometer (SELV/PELV)		AC 24 V ~ / DC 24...48 V =	
	Insulation resistance between potentiometer and housing		AC 500 V ~	

<b>Auxiliary switches (GLB146.1E, GLB166.1E, GLB346.1E)</b>		
Switching voltage		AC 24..250 V ~ / DC 12...30 V =
Contact rating		6 A resistive, 2 A inductive, min. 10 mA @ AC 4 A resistive, 2 A inductive, min. 10 mA @ DC 30 V = 0.8 A resistive, 0.5 A inductive, min. 10 mA @ DC 60 V =
Electric strength aux. switch against housing		AC 4 kV
Switching range for aux. switches		5...90°
	Setting increments	5°
Factory setting	Switch A	5°
	Switch B	85°

<b>Connection cables</b>	
Cable length	0.9 m
Cross section of pre-wired connection cables	0.75 mm <sup>2</sup>
Permissible length for signal lines	300 m

<b>Degree of protection</b>		
Insulation class		As per EN 60730
	AC 24 V / DC 24...48 V, feedback potentiometer	III
	AC 100...240 V, aux. switches	II
Housing protection		IP54 as per EN 60529

<b>Environmental conditions</b>		
Operation		IEC 60721-3-3
	Climatic conditions	Class 3K5
	Mounting location	interior, weather-protected
	Temperature (extended)	-32...55 °C
	Humidity (non-condensing)	<95 % r.h.
Transport		IEC 60721-3-2
	Climatic conditions	Class 2K3
	Temperature (extended)	-32...70 °C
	Humidity (non-condensing)	<95 % r.h.
Storage		IEC 60721-3-1
	Climatic conditions	Class 1K3
	Temperature (extended)	-32...50 °C
	Humidity (non-condensing)	<95 % r.h.
Mechanical conditions		Class 2M2

Standards, directives and approvals	
Product standard	EN 60730 Part 2-14: Particular requirements for electric actuators
Electromagnetic compatibility (applications)	For use in residential, commercial, light-industrial and industrial environments
EU conformity (CE)	A5W00000176 <sup>2)</sup>
UK conformity (UKCA)	A5W00198019A <sup>2)</sup>
RCM conformity	A5W00000177 <sup>2)</sup>
EAC conformity	Eurasian conformity
UL certification	UL as per UL 60730 <a href="http://ul.com/database">http://ul.com/database</a> cUL as per CSA-C22.2 No. 24-93

Environmental compatibility
The product environmental declaration A5W00026066 <sup>2)</sup> contains data on environmentally compatible product design and assessments (RoHS compliance, materials composition, packaging, environmental benefit, disposal).

Dimensions and weight		
Actuator W x H x D		See Dimensions [▶ 11]
Damper shaft		
	Round	8...16 mm
	Round	8...10 mm (with centering element)
	Square	6...12.8 mm
	Min. shaft length	20 mm
	Max. hardness	300 AV
Weight (without packaging)	without switches	Max. 0.49 kg
	with switches	Max. 0.63 kg

<sup>1)</sup> C-UL: permitted only to DC 30 V =

<sup>2)</sup> The documents can be downloaded from <http://siemens.com/bt/download>.



Internal diagrams

GLB14..1E, GLB34..1E: open-close, three-position control

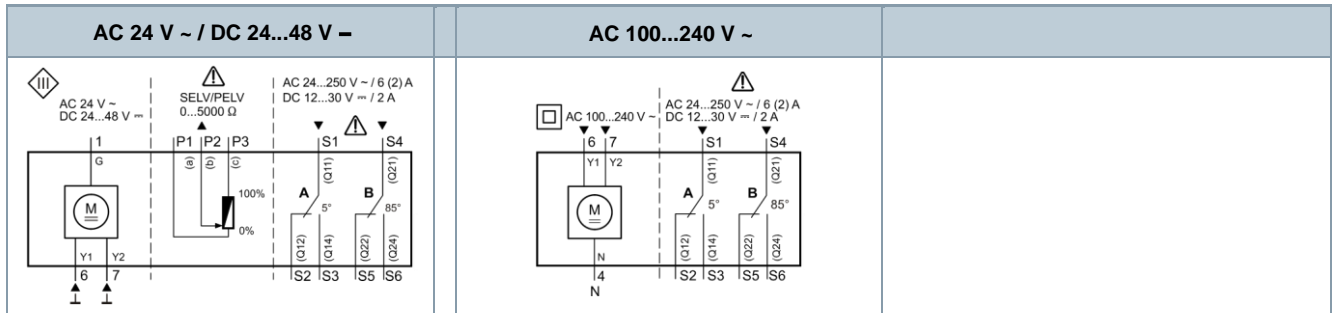

GLB16..1E, GLB36..1E: modulating control

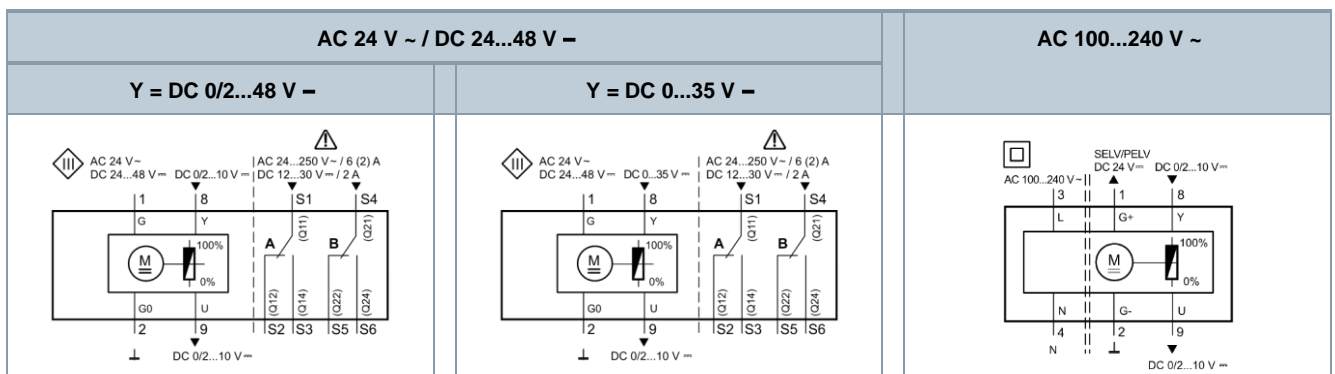

Connection diagrams

GLB1..1E (AC 24 V ~ / DC 24...48 V -)

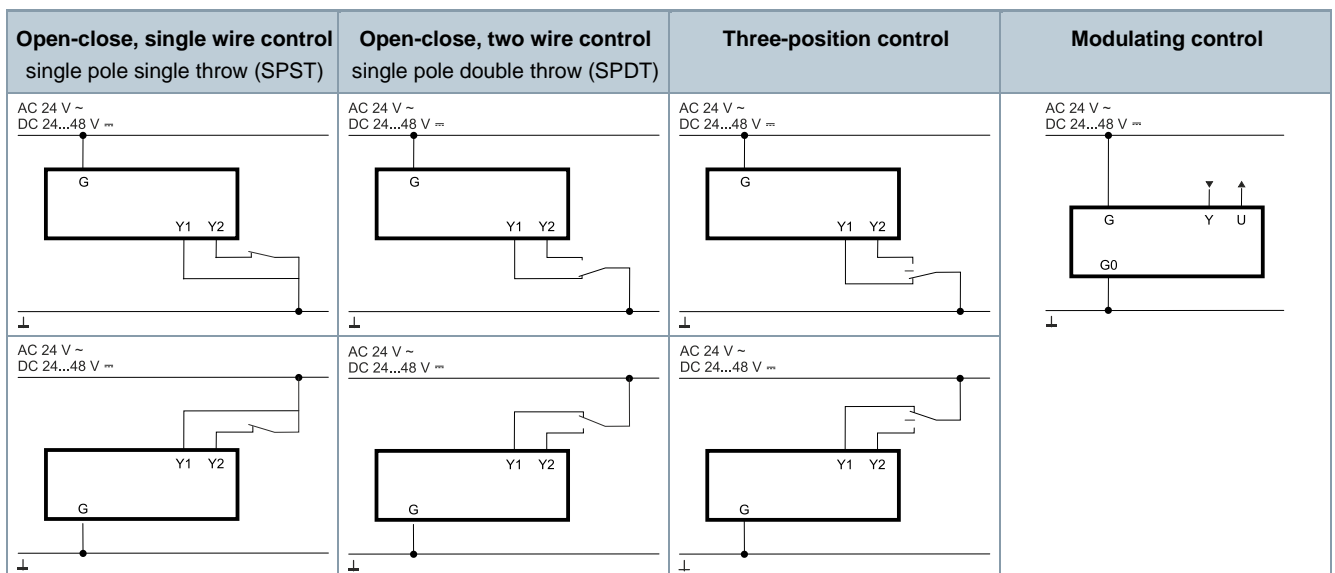

## GLB3..1E (AC 100...240 V ~)

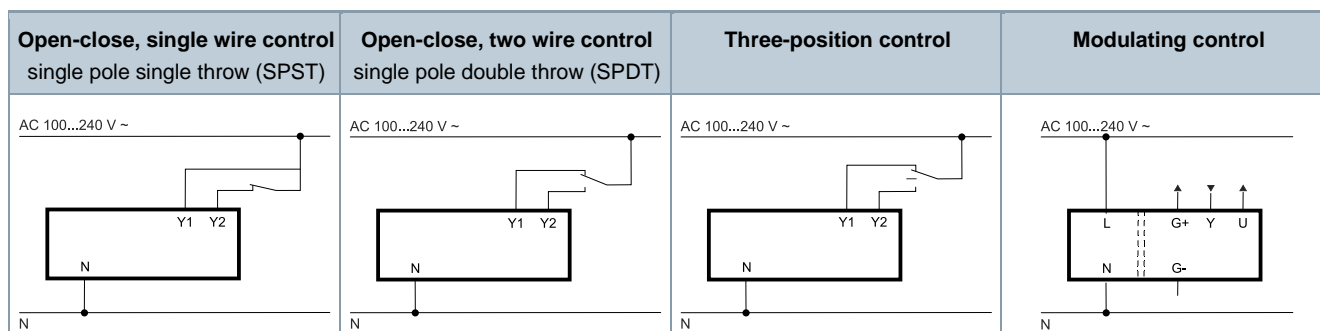

### Cable labeling

Connection	Code	No.	Color	Abbreviation	Meaning
Actuators AC 24 V ~ DC 24...48 V =	G	1	red	RD	System potential AC 24 V ~ / DC 24...48 V =
	G0	2	black	BK	System neutral
	Y1	6	purple	VT	Positioning signal AC/DC 0 V "clockwise" (GLB14..1E)
	Y2	7	orange	OG	Positioning signal AC/DC 0 V "counter-clockwise" (GLB14..1E)
	Y	8	gray	GY	Signal in (GLB16..1E)
	U	9	pink	PK	Signal out (GLB16..1E)
Actuators AC 100...240 V ~	L	3	brown	BR	Line AC 100...240 V ~
	N	4	light blue	BU	Neutral conductor
	Y1	6	black	BK	Positioning signal AC 100...240 V ~ "clockwise" (GLB34..1E)
	Y2	7	white	WH	Positioning signal AC 100...240 V ~ "counter-clockwise" (GLB34..1E)
	G+	1	red	RD	System potential DC 24 V = (aux. power supply) (GLB36..1E)
	G-	2	black	BK	System neutral (aux. power supply) (GLB36..1E)
	Y	8	gray	GY	Signal in (GLB36..1E)
	U	9	pink	PK	Signal out (GLB36..1E)
Feedback potentiometer	a	P1	white/red	WH RD	Potentiometer 0...100 % (P1-P2)
	b	P2	white/blue	WH BU	Potentiometer pick-off
	c	P3	white/pink	WH PK	Potentiometer 100...0 % (P3-P2)
Auxiliary switches	Q11	S1	gray/red	GY RD	Switch A input
	Q12	S2	gray/blue	GY BU	Switch A normally closed contact
	Q14	S3	gray/pink	GY PK	Switch A normally open contact
	Q21	S4	black/red	BK RD	Switch B input
	Q22	S5	black/blue	BK BU	Switch B normally closed contact
	Q24	S6	black/pink	BK PK	Switch B normally open contact

## Dimensions

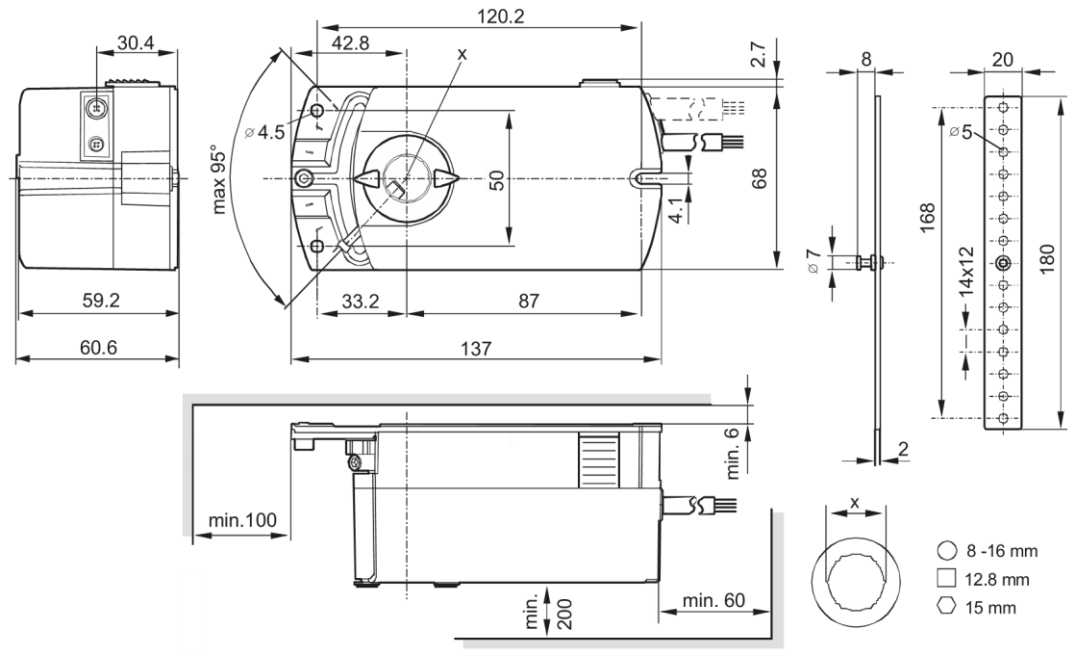

Dimensions in mm

## Revision numbers

Type	Valid from rev. no.	Type	Valid from rev. no.
GLB141.1E S55499-D192	..B	GLB164.1E S55499-D272	..B
GLB142.1E S55499-D193	..B	GLB166.1E S55499-D273	..B
GLB146.1E S55499-D194	..B	GLB341.1E S55499-D195	..B
GLB161.1E S55499-D270	..B	GLB346.1E S55499-D196	..B
GLB163.1E S55499-D271	..B	GLB361.1E S55499-D197	..B

Issued by  
Siemens Switzerland Ltd  
Smart Infrastructure  
Global Headquarters  
Theilerstrasse 1a  
CH-6300 Zug  
+41 58 724 2424  
[www.siemens.com/buildingtechnologies](http://www.siemens.com/buildingtechnologies)

© Siemens Switzerland Ltd, 2016  
Technical specifications and availability subject to change without notice.

---

Document ID    A6V10636202\_en--\_d  
Edition        2023-03-01